

**INSTRUCTIONS FOR FITTING LEGSHIELDS TO
ROYAL ENFIELD MOTORCYCLES**

THIS METHOD OF FITTING COMMON TO ALL MODELS.
ANGULAR SUPPORT STRAP A, WITH CLIP,
TO BE FASTENED TO FRONT DOWN TUBE.
STRAIGHT SUPPORT STRAP B,
TO BE FITTED BETWEEN A & C

THIS FITMENT USED ON MODELS R.E. REC & ENSIGN
ONLY. THE LONG STRAP D FITS IN FRONT OF
THE FRAME TUBE, AND AS THE ENDS ARE
SET AT A SMALL ANGLE MUST BE
ASSEMBLED IN CORRECT RELATION TO
THE LEGSHIELD BLADE.
STRAP D, FITS BEHIND FRAME TUBE AS
ILLUSTRATED FOR MODEL R.E.

... THESE CLIPS USED ON
MODELS C.O. G. J. & S. S.I.
BOTTOM LEGSHIELD CLIPS E,
FIT TO FRAME CRADLE TUBES,
ONE ON EACH SIDE OF ENGINE.

BOTTOM LEGSHIELD CLIPS
F, FOR CLIPPER, MODEL
CLIPS FIT TO SPECIAL STUD
THROUGH CRANKCASE BODY

... THESE CLIPS USED ON
BULLET & TWIN MODELS
ONLY. CLIPS G, FIT TO
SPECIAL STUD THROUGH
FRONT LUG ON CRANKCASE

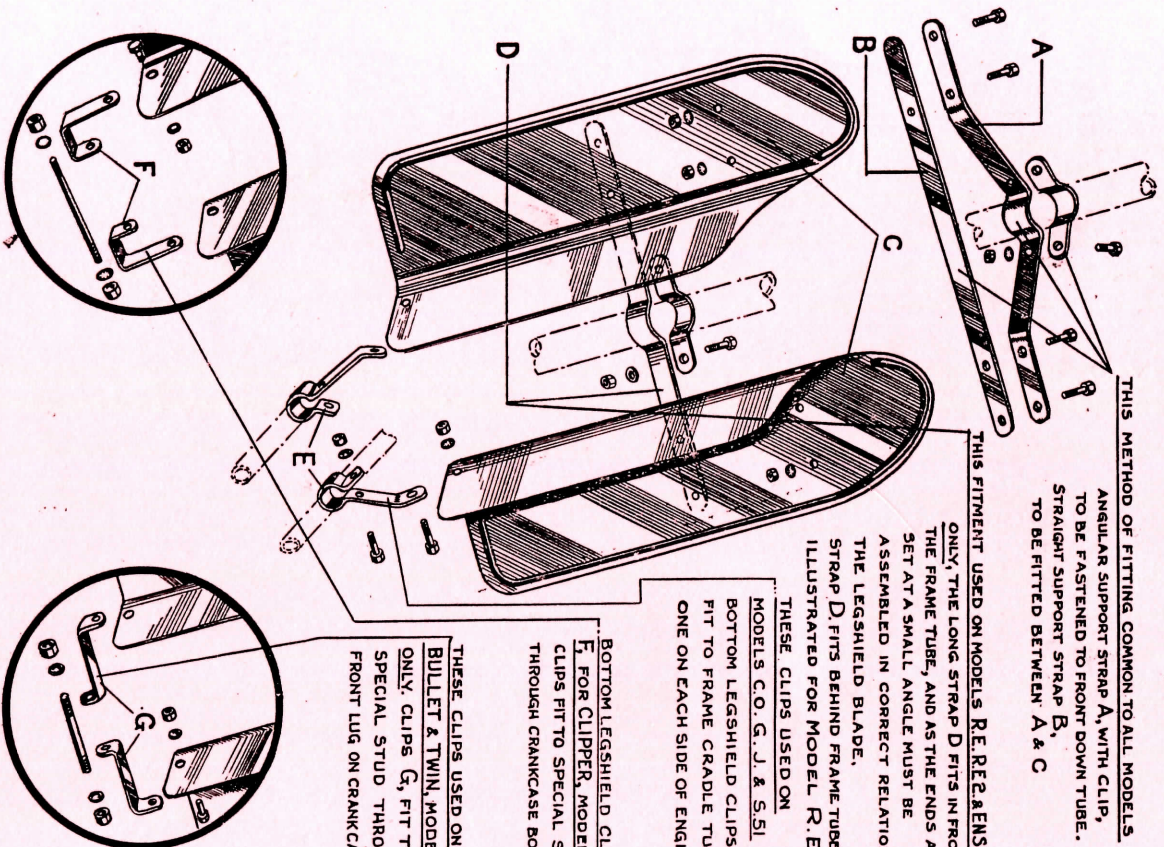

Ref. 417/IM.1054.