

1927

26

ROYAL ENFIELD

MADE LIKE A GUN

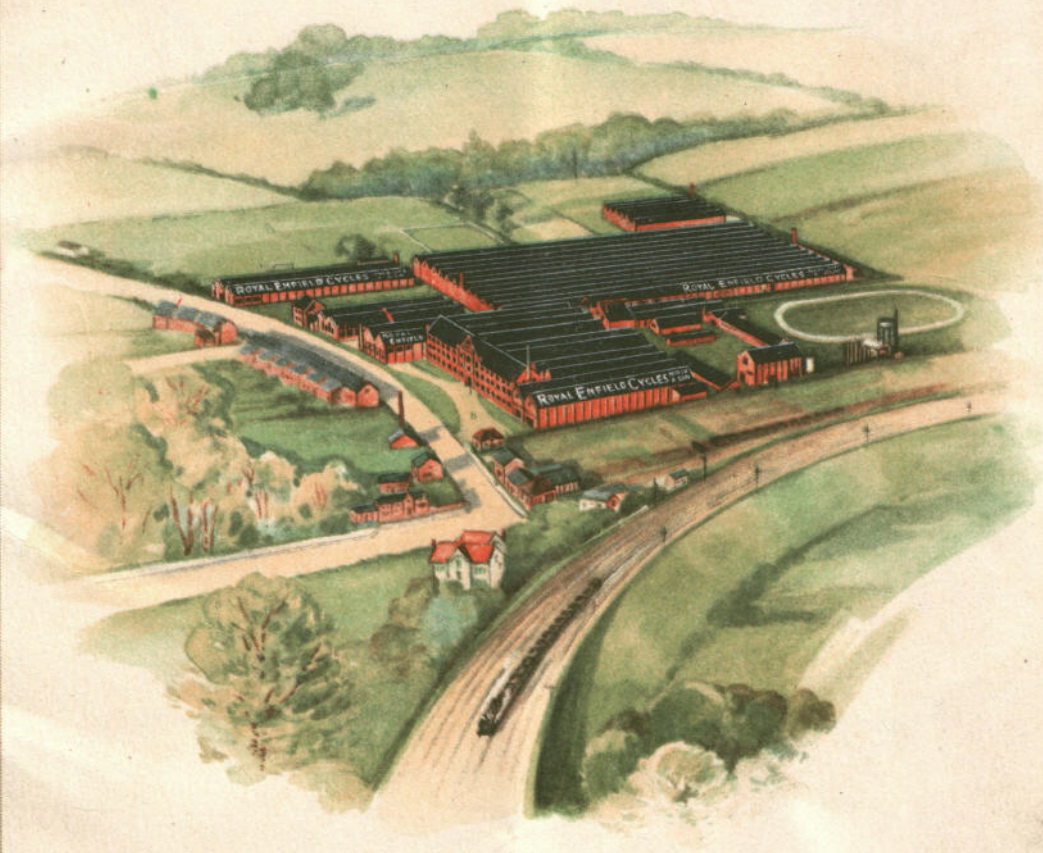

MOTOR CYCLES

ROYAL ENFIELD
MADE LIKE A GUN

Motor Cycles for 1927



THE ENFIELD CYCLE CO. LTD.

HEAD OFFICE & WORKS

REDDITCH

Telephone: Redditch 121 (5 lines)

Telegrams: "Cycles, Redditch"

LONDON OFFICE & SHOWROOMS
48 HOLBORN VIADUCT, E.C.1

Telephones: 5822 and 5823 Holborn
Telegrams: "Jigger, Cent, London"

LONDON SERVICE DEPOT
5, 7, 9 HATTON WALL, HATTON GARDEN, E.C.1

Telephone: 2508 Holborn

BIRMINGHAM OFFICE & SHOWROOMS
274a BROAD STREET

Telephone: 3532 Midland

*Contractors to H.M. Government, the French and Belgian Governments, and
the former Russian Imperial Military Authorities*

ROYAL ENFIELD

FOR 1927 several improvements are included in the specifications of Royal Enfield Motor Cycles, and an entirely new model is introduced. Large section tyres of the wired-on type are fitted on most models. The cylinders of the 9.76 h.p. machines are improved, and have larger exhaust ports; also new and very efficient silencing arrangements. The question of silence has also received attention on the 3.46 h.p. models. A new O.H.V. Royal Enfield engine is fitted to Model 351. The rocker gear is now enclosed, and lubricated from the mechanical pump. Results of tests show that the new engine combines the acceleration and speed of the O.H.V. type with the reliability of the side-valve one. Model 351 is strongly recommended as a machine for reliable fast touring. No alteration has been made to the 2.25 h.p. machines, which have been so consistently successful in their new forms during the past season. The 4.88 h.p. Model, illustrated and described on page 13, is an **entirely new machine**, with Enfield side-valve engine of 488 c.c. and **four-speed gear box**, in addition to the well-known Royal Enfield features of cush drive rear hub, internal expanding brakes, detachable mudguard and carrier, mechanical lubrication, etc.

ENFIELD WORKS

All Royal Enfield Motor Cycles are manufactured in the large and up-to-date works at Redditch, covering nearly twenty acres. The illustration on the cover is a reproduction of a photograph taken from an aeroplane, and conveys an impression of the large size and ideal situation of the works. The roomy workshops are equipped with the most modern machinery. Only the best quality materials are used, and all parts to be enamelled are treated by a special rust-proof process, while those to be plated are first highly polished. The smallest parts are subjected to the most minute scrutiny.

PATENT CUSH DRIVE HUB

The Enfield patent cush drive hub, which is fitted in the rear wheel of all Royal Enfield Motor Cycles, takes up the drive from the countershaft with great flexibility and smoothness. It minimises any tendency to "snatching" or harshness, which some chain drives possess. The wonderful efficiency of this cush drive hub will be readily understood when we say that we are supplying large quantities of similar hubs to other manufacturers. The accompanying illustration shows the inside of the driving sprocket and the outside of the hub. The driving end of the hub is provided with three metal vanes, and the inside of the sprocket is similarly fitted. At each side of the metal vanes in the hub is placed a block of solid rubber. When in position the rubber blocks act as buffers between the vanes.

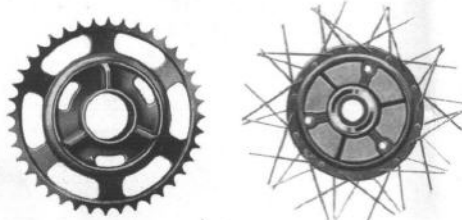

INTERNAL EXPANDING BRAKES

All Royal Enfield Motor Cycles have internal expanding brakes to both wheels. These brakes are of Enfield manufacture, and are strongly made and most efficient. They are smooth in operation but very powerful, the shoes being lined with a compressed asbestos fabric. The brake drums on the 9.76 h.p. machines are eight inches in diameter. The illustration shows details of one of this type. Our patent cush drive hubs embodying these brakes are being supplied to other well-known manufacturers.

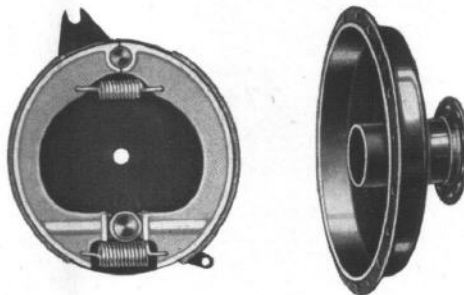

ROYAL ENFIELD

MECHANICAL LUBRICATION

An important feature in the 9'76 h.p., 4'88 h.p., and 3'46 h.p. engines is the Royal Enfield system of mechanical lubrication. The oil pump consists of an oscillating plunger, driven by a spiral gear from the timing wheel. It supplies a continuous and certain supply of oil to the engine, varying in amount according to the speed at which the engine is running. In the case of each engine the supply is sufficient to keep the engine properly lubricated at normal speeds. An auxiliary hand pump is provided to supplement the supply from the mechanical pump when conditions call for greater power, as when ascending long hills or travelling at high speeds.

DETACHABLE REAR MUDGUARD AND CARRIER

To facilitate tyre repairs and the removal of the rear wheel, the carrier and rear mudguard of all Royal Enfield Motor Cycles are made quickly detachable. The accompanying illustration shows the carrier and guard lifted clear. To do this

slacken the nuts A on either side of the rear fork ends, which retain the carrier supports. The carriers should then be tapped sharply upwards, and the hooked ends B will lift out of the sockets C. The whole assembly of carrier and mudguard can then be lifted away, and the rear wheel and tyre are at once easily accessible.

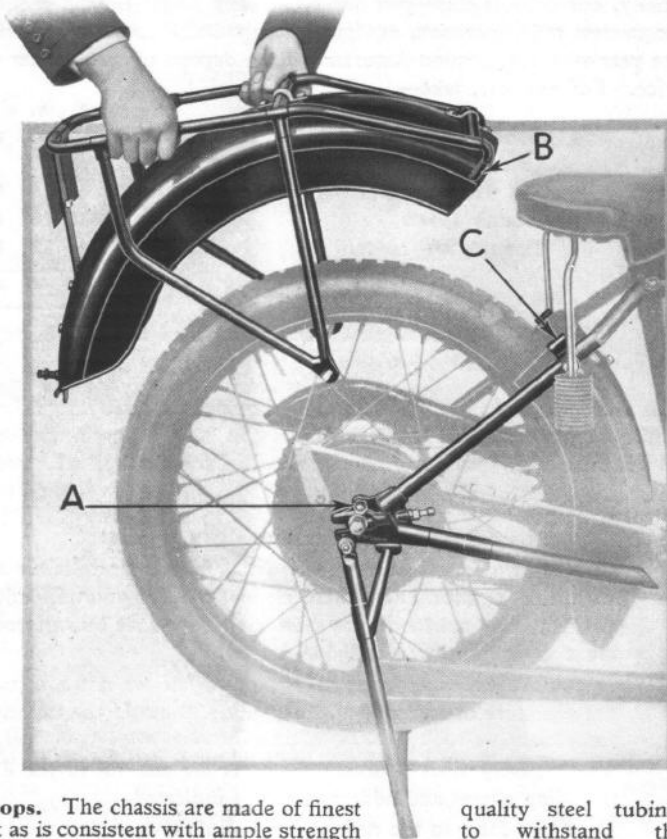

SIDE-CARS

The sidecars fitted to Royal Enfield Motor Cycles are all made throughout

in our own shops. The chassis are made of finest quality steel tubing, and are as light as is consistent with ample strength to withstand the demands put upon them. Specially selected ash is used for the framework of the bodies, and the panels are of sheet metal or polished aluminium on a foundation of three-ply wood. The upholstery is black grained leather cloth. We illustrate several types of trade delivery carriers made by us. We are always willing, when it is practicable, to make bodies varying slightly from the printed specifications in order to meet the requirements of our clients, but this, of course, entails additional expense.

ROYAL ENFIELD AGENTS

In almost every town and village in Great Britain and Ireland an accredited Royal Enfield agent will be found. In addition to this, we are also represented in most parts of the world. Our representation is in the hands of experienced motor cycle men, who willingly place their services at the disposal of potential buyers. We shall be pleased to furnish you with the name and address of the nearest Royal Enfield agent.



To ENFIELD CYCLE (Gradual Payments) LTD.
48, Holborn Viaduct, London, E.C.1

Name (in full)..... Occupation

(BLOCK LETTERS, PLEASE) Are you a Householder?

Address (If you are not, a guarantor is required below.)

..... Age (if under 21 years).....

..... 19.....

DEAR SIRS,

I desire a Royal Enfield Motor Cycle and Accessories as detailed below in accordance with the terms you offer. I enclose a deposit of £....., and I will pay the appropriate monthly payments at their due date. I understand you will embody these figures in an agreement and send this to me for *my approval* and signature. If I do not desire to complete the transaction, you will return my deposit in full.

Yours faithfully,

MODEL.....ENFIELD.

With.....MODEL SIDECAR.

Accessories—

REFERENCES' NAMES AND ADDRESSES.
 (Their letters should accompany this form to save delay.)

(1)

.....

.....

(2)

.....

.....

Specially Note I Require—

GUARANTOR'S NAME AND ADDRESS.
 If necessary (that is if you are under 21 years of age or are not a householder).

Name (in full).....

.....

.....

Occupation

Are you a Householder?

ACCESSORIES

The following Accessories *only* can be included above :

Various Models.—Coweys Speedometer, £3 15s 0d.; Legshields, Electric Lighting, Hoods, Windscreens, Balloon Tyres, etc., at Catalogue Prices.

Models 200, 201, 201A.—	£	s.	d.
Lucas No. 331 S. Head Light and Generator	1	8	0
Lucas No. 344 Rear Light and Generator	0	13	0
Lucas No. 63 E. B. Bulb Horn	0	10	6
Models 350, 351, and 500.—			
Lucas No. 342 F. S. Head Light and Generator	1	14	0
Lucas No. 350 Sidecar Light and Generator.. ..	0	16	6
Lucas No. 344 Rear Light and Generator	0	13	0
Lucas No. 63 E. B. Bulb Horn	0	10	6
Models 180, 182, 185, 175, 165, 155 —			
Lucas No. 462 F. S. Head Light and Generator	3	3	0
Lucas No. 354 Sidecar Light and Generator.. ..	1	2	6
Lucas No. 344 Rear Light and Generator	0	13	0
Lucas No. 63 E. B. Bulb Horn	0	10	6
Lucas No. 60 E. B. Bulb Horn	0	15	6

INSURANCE.—Full details overleaf.



**To ENFIELD CYCLE (Gradual Payments) LTD.
48, Holborn Viaduct, London, E.C.1**

Name (in full)..... Occupation
 (BLOCK LETTERS, PLEASE) Are you a Householder?
 Address (If you are not, a guarantor is required below.)
 Age (if under 21 years).....
 19.....

DEAR SIRs,

I desire a Royal Enfield Motor Cycle and Accessories as detailed below in accordance with the terms you offer. I enclose a deposit of £....., and I will pay the appropriate monthly payments at their due date. I understand you will embody these figures in an agreement and send this to me for my approval and signature. If I do not desire to complete the transaction, you will return my deposit in full.

Yours faithfully,

MODEL.....ENFIELD.

With.....MODEL SIDECAR.

Accessories—

Specially Note I Require—

REFERENCES' NAMES AND ADDRESSES.
 (Their letters should accompany this form to save delay.)

- (1)

 (2)

GUARANTOR'S NAME AND ADDRESS.
 If necessary (that is if you are under 21 years of age or are not a householder).

Name (in full).....

 Occupation
 Are you a Householder?

ACCESSORIES

The following Accessories only can be included above :

Various Models.—Cowey Speedometer, £3 15s 0d.; Legshields, Electric Lighting, Hoods, Windscreens, Balloon Tyres, etc., at Catalogue Prices.

Models 200, 201, 201A.—	£	s.	d.
Lucas No. 331 S. Head Light and Generator	1	8	0
Lucas No. 344 Rear Light and Generator	0	13	0
Lucas No. 63 E. B. Bulb Horn	0	10	6
Models 350, 351, and 500.—			
Lucas No. 342 F. S. Head Light and Generator	1	14	0
Lucas No. 350 Sidecar Light and Generator.. ..	0	16	6
Lucas No. 344 Rear Light and Generator	0	13	0
Lucas No. 63 E. B. Bulb Horn	0	10	6
Models 180, 182, 185, 175, 165, 155 —			
Lucas No. 462 F. S. Head Light and Generator	3	3	0
Lucas No. 354 Sidecar Light and Generator.. ..	1	2	6
Lucas No. 344 Rear Light and Generator	0	13	0
Lucas No. 63 E. B. Bulb Horn	0	10	6
Lucas No. 60 E. B. Bulb Horn	0	15	6

INSURANCE.—Full details overleaf.

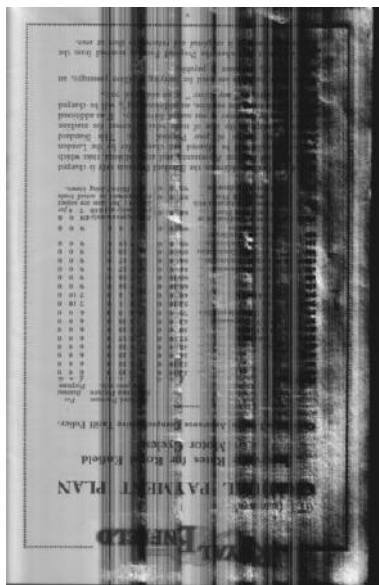

ROYAL ENFIELD

MADE TIME A GUN

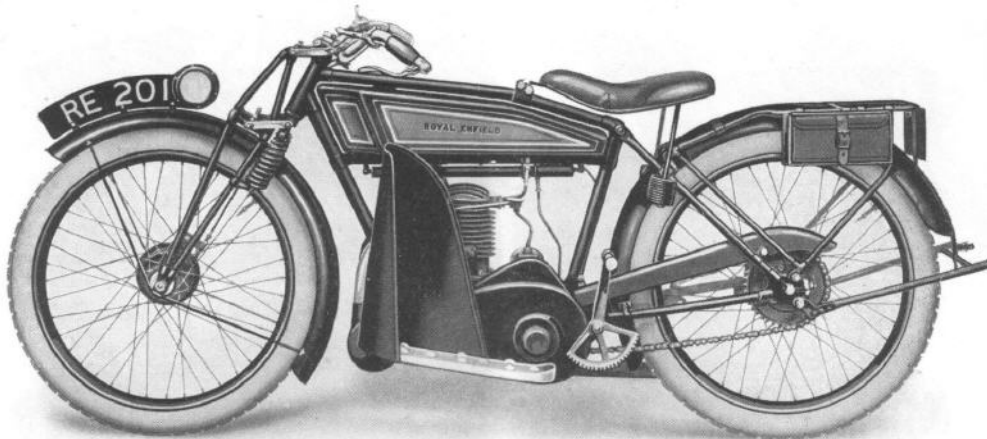

2.25 h.p. Standard Model 201 (Tax 30/-)

SPECIFICATION :

ENGINE.—Royal Enfield Two-Stroke; bore and stroke 64 × 70 m/m.; capacity 225 c.c. Two exhaust ports. Roller bearings throughout.

LUBRICATION.—Oil mixed with petrol.

IGNITION.—High tension Magneto placed behind cylinder.

CARBURETTER.—Special two-lever type.

GEAR.—Royal Enfield $\frac{1}{2}$ two-speed. Handlebar-controlled clutch and kick-starter. Standard ratios 8:1 to 1 and 5 to 1.

TRANSMISSION.—Roller chains. Patent Cush Drive in rear hub.

FRAME.—Low and comfortable riding position. Aluminium Footboards and protective Legshields. Royal Enfield Front Forks.

HANDLEBAR.—Touring or Sporting type; both adjustable.

BRAKES.—Internal expanding, front and rear.

SADDLE.—Best quality; long suspension springs.

TYRES.—Dunlop Cord 24 × 2½ in.

MUDGUARDS.—Strong and efficient.

CARRIER.—Detachable carrier. By unfastening two nuts, the carrier and rear mudguard are lifted clear of the back wheel and tyre.

TOOL BAG.—Strong leather, containing a complete set of tools.

FINISH.—Enamelled in Best Black Enamel. Tank artistically panelled and lined. Bright parts heavily plated.

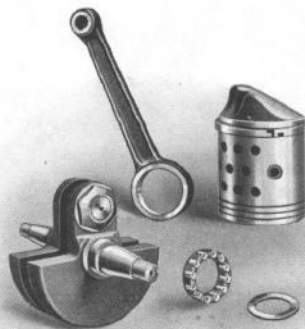

Piston, connecting rod, crank shaft, and roller bearing details of Royal Enfield two-stroke engine.

WEIGHT.—Approx. 160 lbs.

LENGTH.—6 ft. 4 in.

WIDTH.—2 ft. 8½ in.

SADDLE HEIGHT.—26½ in.

Price - £32 10 0 net cash

or £9 1s. 3d. down, and twelve monthly instalments of £2 9s. 0d., including insurance.

This Model can be supplied fitted with Electric Lighting Set at an extra charge of £7.

ROYAL ENFIELD

MADE LIKE A GUN

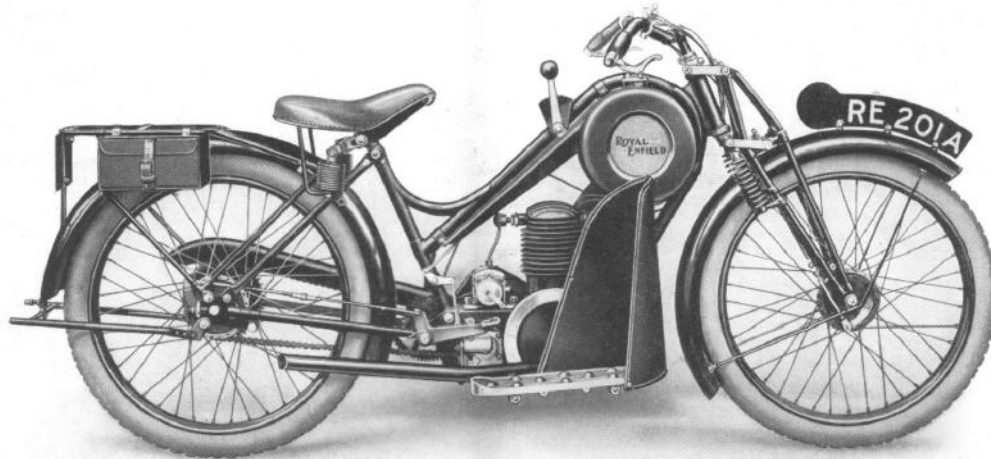

2·25 h.p. Open-frame Model 201a

(Tax 30/-)

Similar in general specification to Model 201, but designed and built for the lady or gentleman who prefers not to wear special clothing when motor cycling. It has a unique frame with circular tank. A dressguard extends rearwards from the tank to protect the rider's clothes.

Price - £34 0 0 net cash

or £9 8 9 down, and twelve monthly instalments of
£2 11 0, including Insurance.

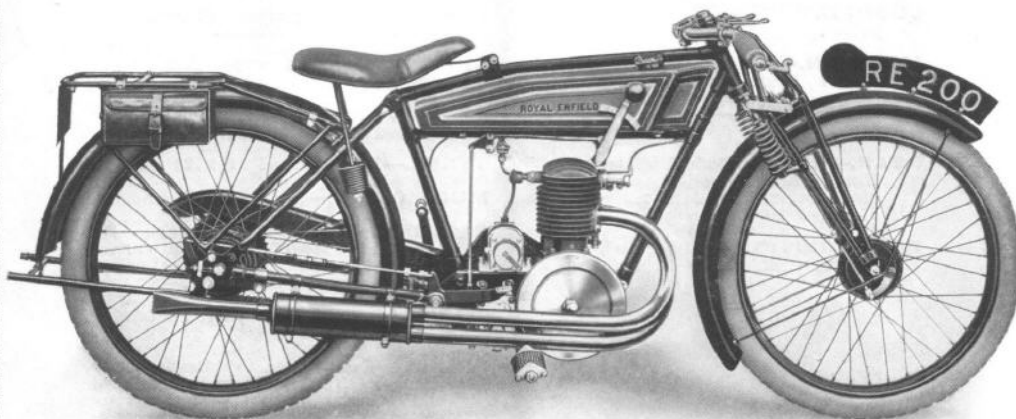

2·25 h.p. Sports Model 200

(Tax 30/-)

This machine has sports-type clip-on handlebar, footrests instead of footboards, and the twin exhaust pipes are carried to a cylindrical silencer on the off-side of the machine. In other respects the specification is similar to that of Model 201

Price - £32 10 0 net cash

or £9 1 3 down, and twelve monthly instalments of
£2 9 0, including Insurance.

These Models can also be supplied fitted with Electric Lighting Set at an extra charge of £7.

ROYAL ENFIELD

MADE LIKE A GUN

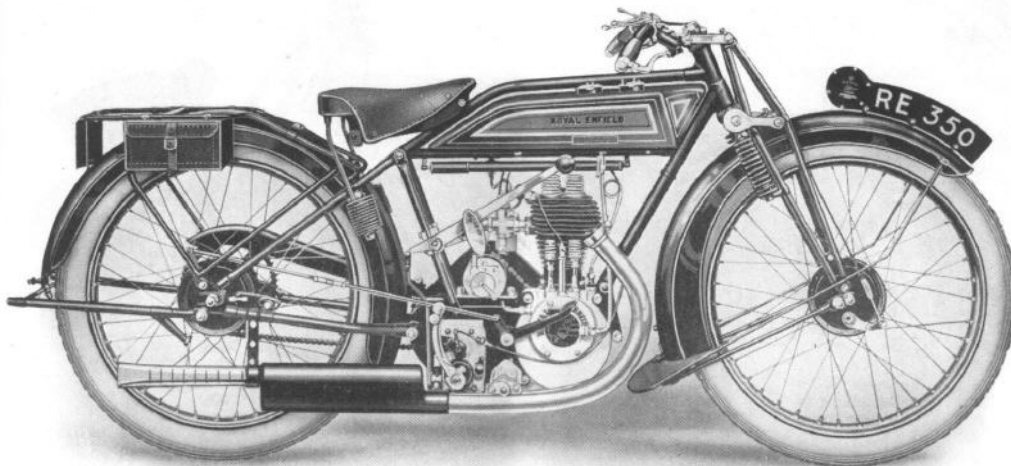

3.46 h.p. Standard Model 350

SPECIFICATION :

ENGINE.—346 c.c. Single Cylinder; bore and stroke 70 × 90 m/m. Aluminium alloy piston; Duralumin connecting rod. Roller bearings throughout.

LUBRICATION.—Automatic mechanical pump and auxiliary hand pump.

IGNITION.—High tension Magneto.

CARBURETTER.—Two-lever type.

GEAR.—Sturmey-Archer three-speed. Handlebar-controlled clutch and kick-starter. Standard ratios: SOLO, high 5.9, middle 8.9, low 17.3; SIDE-CAR, high 6.7, middle 10, low 19.5.

TRANSMISSION.—Roller chains. Patent Cush Drive in rear hub.

FRAME.—Low saddle position. Royal Enfield Front Forks with shock absorbers. Footrests (Footboards and Legshields extra).

SADDLE.—Terry or Lycett Spring Seat; long suspension springs.

BRAKES.—Internal expanding, front and rear (5 in. drums).

HANDLEBAR.—Touring or Sports; adjustable.

TYRES.—Dunlop Cord 27 × 2.75 in.

MUDGUARDS.—Strong and efficient.

CARRIER.—Detachable carrier. By unfastening two nuts, the carrier and rear mudguard are lifted clear of the back wheel and tyre.

STANDS.—Front and rear.

TOOLS.—Complete set in two pannier bags on carrier.

FINISH.—Best quality Black Enamel. Tank panelled and lined. Bright parts heavily plated.

WEIGHT.—Approx. 210 lbs.

WIDTH.—2 ft. 8½ in.

LENGTH.—6 ft. 9 in.

SADDLE HEIGHT.—29 in.

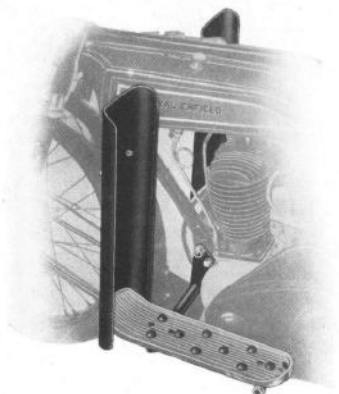

Footboards and legshields on Model 350,
25s. extra.

Price - £45 net cash

or £12 3s. 9d. down, and twelve monthly instalments of £3 5s. 10d., including Insurance.

Electric Lighting Set, £7 extra.

Price with either Model 12 or Model 14 Sidecar (illustrated on page 12)

£57 0 0

or £15 4s. 6d. down, and twelve monthly instalments of £4 2s. 3d., including Insurance.

ROYAL ENFIELD

MADE LIKE A GUN

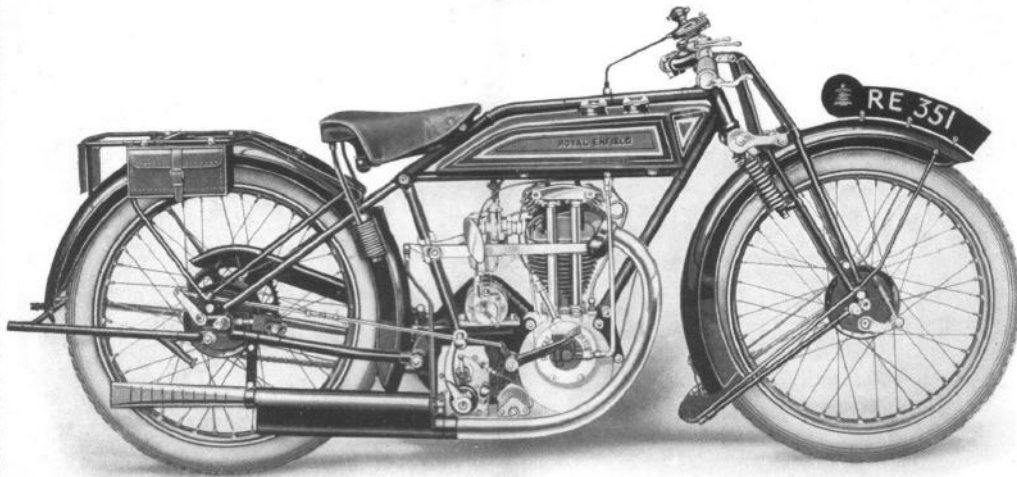

3.46 h.p. O.H.V. Sports Model 351

SPECIFICATION :

ENGINE.—New improved 346 c.c. O.H.V. Single Cylinder; bore and stroke 70 × 90 m/m. Aluminium alloy piston; Duralumin connecting rod. Roller bearings. Enclosed rockers, lubricated by mechanical pump.

LUBRICATION.—Automatic mechanical pump and auxiliary hand pump.

IGNITION.—High tension Magneto.

CARBURETTER.—Two-lever type.

GEAR.—Sturmey - Archer three-speed (close ratio). Handlebar-controlled clutch and kick-starter. Standard ratios: SOLO, high 5.3, middle 7.7, low 11.5; SIDECAR, high 5.9, middle 7.8, low 12.8.

TRANSMISSION.—Roller chains. Patent Cush Drive in rear hub.

FRAME.—Low saddle position. Foot-rests. Royal Enfield Front Forks with shock absorbers and steering damper.

SADDLE.—Terry or Lycett Spring Seat.

BRAKES.—Internal expanding, front and rear (5 in. drums).

HANDLEBAR.—Sports type, adjustable; long rubber grips.

WEIGHT.—Approx. 224 lbs.

SADDLE HEIGHT.—29 in.

LENGTH.—6 ft. 9 in.

WIDTH.—2 ft. 9½ in.

Price - £50 net cash

or £13 8s. 9d. down, and twelve monthly instalments of £3 12s. 7d., including Insurance.

Electric Lighting Set, £7 extra.

Price with either Model 12 or Model 14 Sidecar (illustrated on page 12)

£62 0 0

or £16 9s. 6d. down, and twelve monthly instalments of £4 9s. 0d., including Insurance.

TYRES.—Dunlop Cord 27 × 2.75 in.

MUDGUARDS.—Strong and efficient.

STANDS.—Front and rear.

CARRIER.—Detachable carrier. By unfastening two nuts, the carrier and rear mudguard are lifted clear of the back wheel and tyre.

TOOLS.—Complete tool kit in two strong pannier bags on carrier.

FINISH.—Best quality Black Enamel. Tank panelled green and gold. Bright parts heavily plated.

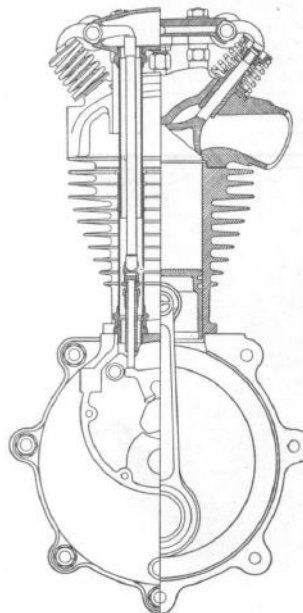

Sectional diagram of 3.46 h.p. O.H.V. engine.

ROYAL ENFIELD

MADE LIKE A GLAY

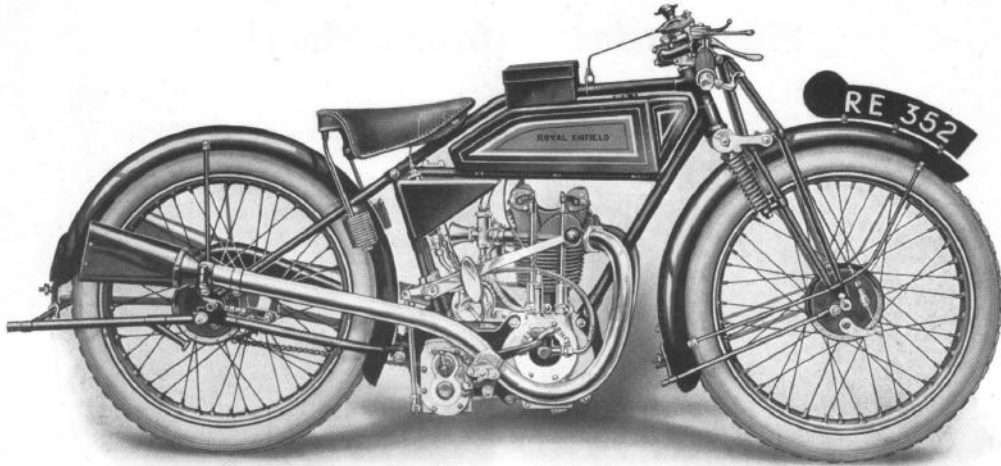

3.44 h.p. O.H.V. (double-port) Sports Model 352

SPECIFICATION :

ENGINE.—344 c.c. O.H.V. Super Sports Single Cylinder; bore and stroke 74 × 80 m/m.; aluminium alloy piston; two exhaust ports. Two long exhaust pipes with detachable silencers.

LUBRICATION.—Automatic mechanical pump and auxiliary hand pump operated by Bowden control from handlebar.

IGNITION.—High tension Magneto.

CARBURETTER.—Racing type.

GEAR.—Sturmey - Archer three - speed (close ratio). Handlebar-controlled clutch. No kickstarter. Standard ratios : high 5'3, middle 7'7, low 11'5.

TRANSMISSION.—Roller chains. Patent Cush Drive in rear hub.

FRAME.—Low saddle position. Adjustable footrests. Royal Enfield front forks with shock absorbers and steering damper. Adjustable handle bars.

SADDLE.—Terry or Lycett Spring Seat.

BRAKES.—Internal expanding to both wheels.

TANKS.—Large tank for petrol only. Separate oil tank on down-tubes beneath saddle. Petroflex pipes throughout.

TYRES.—Dunlop Cord 27 × 2.75 in.

MUDGUARDS.—Lightweight racing type. A carrier is not fitted.

STANDS.—Front and rear.

TOOLS.—Tool kit in strong leather bag on top tube.

FINISH.—Best quality black enamel. Petrol tank panelled green and gold. Bright parts heavily plated.

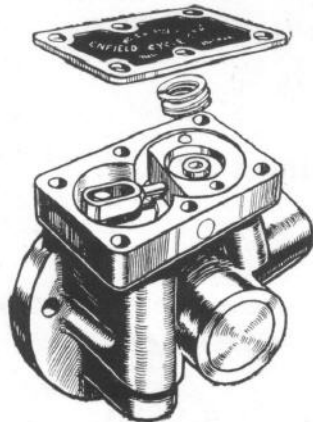

Sketch of Mechanical Oil Pump, as fitted to 3.46 h.p., 4.88 h.p. and 9.76 h.p. machines.

WEIGHT.—Approx. 242 lbs.

LENGTH.—6 ft. 9 in.

WIDTH.—2 ft. 9½ in.

SADDLE HEIGHT.—29 in.

Price - £75 net cash

or £19 15s. 0d. down, and twelve monthly instalments of £5 6s. 8d., including Insurance.

ROYAL ENFIELD

MADE LIKE A GUY

Sidecars for 3.46 h.p. Models

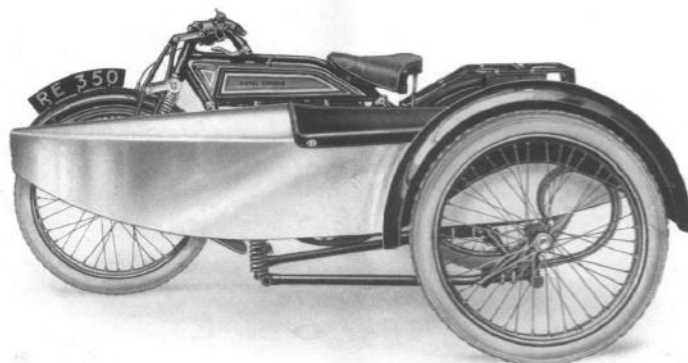

Sports Sidecar Model 14

SPECIFICATION:

CHASSIS.—Enfield design; four-point attachment. Cee springs at rear and coil springs in front.

TYRE.—Dunlop Cord 27 × 2.75 in.

BODY.—Sturdily built and panelled in polished aluminium. Upholstered in

black leather cloth. Hammock seat. Locker for tools and spares behind seat back. Cover-all apron fitted. Mudguard attached.

LENGTH of Sidecar, 6 ft. 4 in.

WEIGHT of Sidecar, Chassis, etc., approximately 100 lbs.

Price - £12 0 0 net cash

or **£3 0s. 9d.** down, and twelve monthly instalments of **16s. 5d.**, including Insurance.

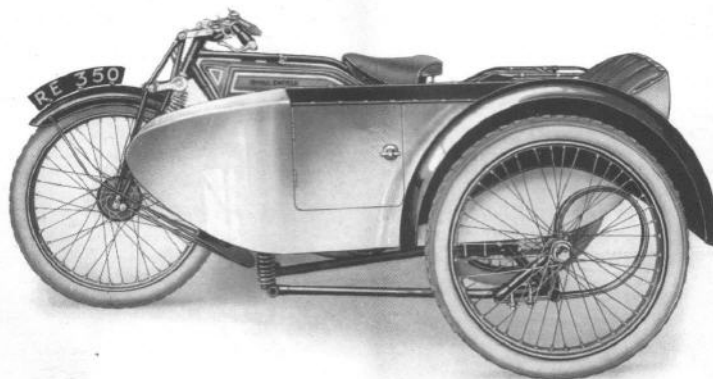

Touring Sidecar Model 12

Similar to specification above, with the exception of the Sidecar Body, which is of touring shape, with door. A spring seat takes the place of the hammock type mentioned above.

Curved celluloid Windscreen can be supplied at **£1** extra.

Length of Sidecar, 4 ft. 9½ in. Weight of Sidecar, Chassis, etc., about 98 lbs.

Overall length of either of above Combinations, 6 ft. 9 in.

Overall width of either of above Combinations, 4 ft. 9 in.

Price - £12 0 0 net cash

or **£3 0s. 9d.** down, and twelve monthly instalments of **16s. 5d.**, including Insurance.

ROYAL ENFIELD

MADE LIKE A GUN

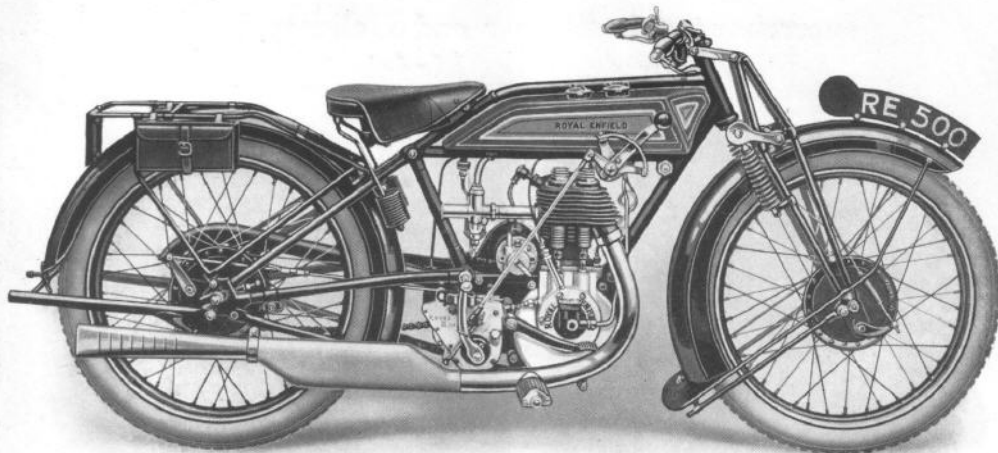

4.88 h.p. Four-speed Gear Model 500

SPECIFICATION :

ENGINE.—488 c.c. Single Cylinder ; bore and stroke 85.5 × 85 m/m. Aluminium alloy piston. Roller bearing big end.

LUBRICATION.—Automatic mechanical pump and auxiliary hand pump.

IGNITION.—High tension Magneto.

CARBURETTER.—Two-lever type.

GEAR.—Enfield four-speed. Handlebar-controlled clutch and kick-starter. Standard ratios : SOLO, 5.1, 6.6, 8.7, and 15.8 ; SIDECAR, 5.8, 7.5, 9.8, and 17.9.

TRANSMISSION.—Roller chains. Patent Cush Drive in rear hub.

FRAME.—Low saddle position. Royal Enfield Front Forks with shock absorbers. Footrests. Sidecar lugs incorporated.

WEIGHT.—Approx. 245 lbs.

LENGTH.—6 ft. 9½ in.

SADDLE.—Terry or Lycett Spring Seat ; long suspension springs.

BRAKES.—Internal expanding, front and rear (6½ in. drums).

HANDLEBAR.—Touring or Sports ; adjustable.

TYRES.—Dunlop Cord 27 × 2.75 in.

MUDGUARDS.—Strong and efficient.

CARRIER.—Detachable carrier. By unfastening two nuts, the carrier and rear mudguard are lifted clear of the back wheel and tyre.

STANDS.—Front and rear.

TOOLS.—Complete set in two pannier bags on carrier.

FINISH.—Best quality Black Enamel. Tank panelled and lined. Bright parts heavily plated.

WIDTH.—2 ft. 8½ in.

SADDLE HEIGHT.—29 in.

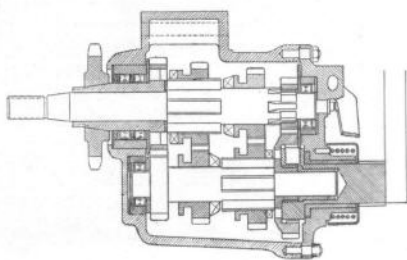

Diagram of Four-speed Gearbox.

Price £52 10 0 net cash

or **£14 12s. 6d.** down, and twelve monthly instalments of **£3 19s. 1d.**, including Insurance.

Electric Lighting Set, £7 extra.

Price with Sidecar or Box Carrier £68
(illustrated on next page)

or (with Sidecar) **£18 11s. 0d.** down, and twelve monthly instalments of **£5 2s. 0d.**, including Insurance.

ROYAL ENFIELD

Interchangeable Sidecar and Delivery Box for 4.88 h.p. Model

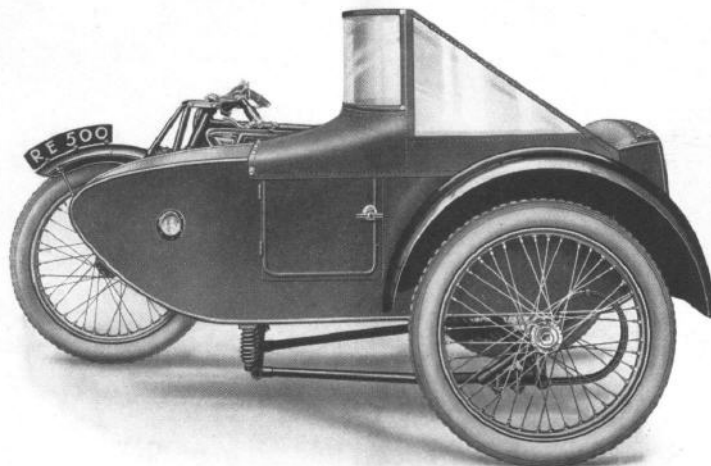

The handsome coach-built Sidecar illustrated is made specially for Model 500, and is finished in dark green to match the motor cycle. The chassis is strong and easily detachable, while the springing is excellent. A curved celluloid wind-screen is a standard fitment, and locker space is provided behind the seat back and under the seat. Upholstery is black leather cloth.

Price - - £15 10 0 net cash

or **£3 18s. 6d.** down, and twelve monthly instalments of **21s.**, including Insurance.

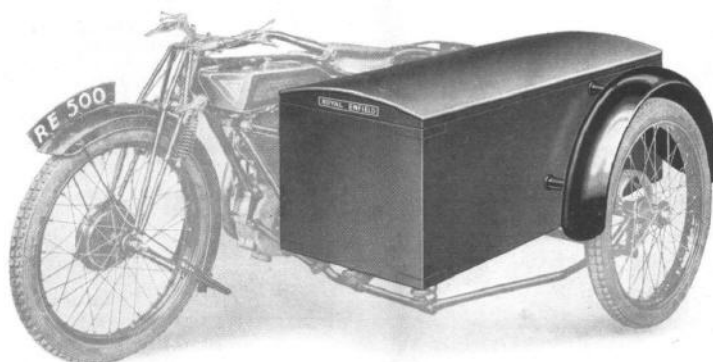

The 4.88 h.p. chassis is designed to take a box carrier in place of the passenger body, if desired. By unfastening four nuts only, the two bodies may be exchanged. The box carrier illustrated is strongly built and painted green. The dimensions are as follows:—Length, 4 ft. 4 in.; depth, 1 ft. 6½ in.; width, 1 ft. 8 in. Lettering on the box will be inscribed at a small extra charge, according to the work done.

Price (of additional Box only) - £9 0 0 net cash

Insurance Rates for Trade Delivery Vehicles vary according to actual trade and district in which used. Gradual payment prices for these Outfits, therefore, can be supplied on receipt of this information.

Overall width of 4.88 h.p. Combination, 4 ft. 10½ in.

ROYAL ENFIELD

MADE LIKE A GUN

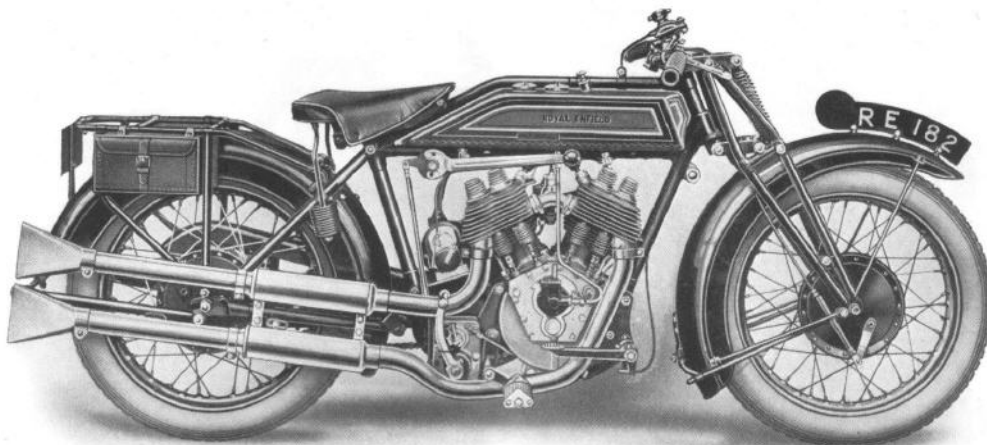

9-76 h.p. Sports Model 182

SPECIFICATION :

- ENGINE.**—Royal Enfield Twin Cylinder; bore and stroke 85.5 x 85 m/m.; capacity 976 c.c.; aluminium alloy pistons.
- LUBRICATION.**—Automatic mechanical pump and auxiliary hand pump.
- IGNITION.**—High tension Magneto.
- CARBURETTER.**—Two-lever.
- GEAR.**—Sturmey-Archer three-speed. Handlebar-controlled clutch and kick-starter. Standard ratios: SOLO, high 4, middle 5.8, low 11.7; SIDECAR, high 4.7, middle 6.9, low 13.8.
- TRANSMISSION.**—Roller chains. Cush Drive Hub in rear wheel.
- TYRES.**—Dunlop Cord 26 x 3.25 in.
- FRAME.**—Very strong and rigid. Wide front forks, with steering damper. Footrests on Solo Models.
- BRAKES.**—Internal expanding, front and rear, with 8 in. drums. Both foot operated.
- STANDS.**—Stands for front and rear wheels.
- CARRIER.**—Detachable carrier. By unfastening two nuts, the carrier and rear mudguard are easily removed.
- HANDLEBAR.**—Semi-T.T. type; adjustable.
- SADDLE.**—Terry or Lycett Spring Saddle.
- TOOLS.**—Complete kit.
- FINISH.**—Best Black Enamel. Tank panelled in green. Bright parts heavily plated.

WEIGHT.—Approx. 308 lbs.

WIDTH.—2 ft. 8 in.

LENGTH.—7 ft. 2 in.

SADDLE HEIGHT.—30 in.

Price - £68 10 0 net cash

or **£19 1s. 3d.** down, and twelve monthly instalments of **£5 2s. 11d.**, including Insurance.

Price with aluminium Sports Sidecar £84
(illustrated on page 17)

or **£22 19s. 6d.** down, and twelve monthly instalments of **£6 4s. 1d.**, including Insurance.

Lucas Magdyno Electric Lighting Set, Lamps, and Bulb Horn,
£10 extra (£11 with Sidecar).

Legshields (illustrated on page 20), **15s.** extra.

Dunlop Cord Balloon Tyres on Combination, **£3 extra.**

ROYAL ENFIELD

MADE LIKE A GUN

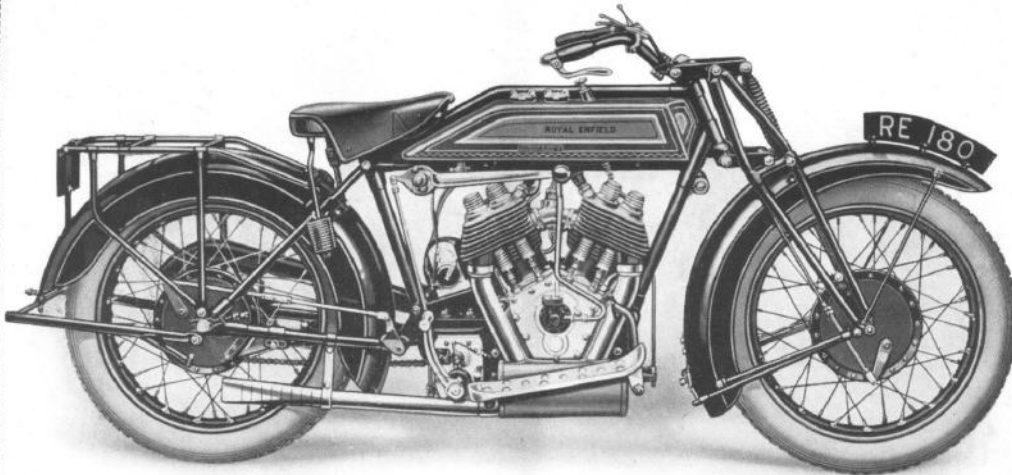

9.76 h.p. Standard Model 180

SPECIFICATION :

- ENGINE.**—Improved Royal Enfield Twin Cylinder; bore and stroke 85.5 × 85 m/m.; capacity 976 c.c.; aluminium alloy pistons. Larger exhaust ports and new silencer.
- LUBRICATION.**—Automatic mechanical pump and auxiliary hand pump.
- IGNITION.**—High tension Magneto.
- CARBURETTOR.**—Two-lever.
- GEAR.**—Sturmey - Archer three - speed. Handlebar-controlled clutch and kick-starter. Standard ratios: high 4.7, middle 6.9, low 13.8.
- TRANSMISSION.**—Roller chains. Cush Drive Hub in rear wheel.
- TYRES.**—Dunlop Cord 26 × 3.25 in.
- BRAKES.**—Internal expanding, front and rear, with 8 in. drums. Both foot operated.
- STANDS.**—Stands for front and rear wheels.
- MUDGUARDS.**—Very wide and strong.
- CARRIER.**—Detachable carrier. By unfastening two nuts, the carrier and rear mudguard are easily removed.
- HANDLEBAR.**—Adjustable.
- SADDLE.**—Terry or Lycett Spring Saddle.
- TOOLS.**—Complete set.
- FINISH.**—Best Black Enamel. Tank panelled in green. Bright parts heavily plated.
- WEIGHT.**—308 lbs.
- OVERALL LENGTH.**—7 ft. 2 in.
- WIDTH.**—2 ft. 6 in.

Price - - £66 10 0 net cash

or **£18 11s. 0d.** down, and twelve monthly instalments of **£5 0s. 2d.**, including Insurance.

Price with Coach-built Touring Sidecar £84
(illustrated on opposite page)

or **£22 19s. 6d.** down, and twelve monthly instalments of **£6 4s. 1d.**, including Insurance.

Legshields (illustrated on page 20), **15s.** extra.

Dunlop Cord Balloon Tyres on Combination, **£3** extra.

The De Luxe (Electrically equipped) Combination is illustrated and described on page 18, Two-seater Sidecars on page 19, and Special Hood Set on page 20.

ROYAL ENFIELD

MADE LIKE A GUN

Sidecars for 9.76 h.p. Models

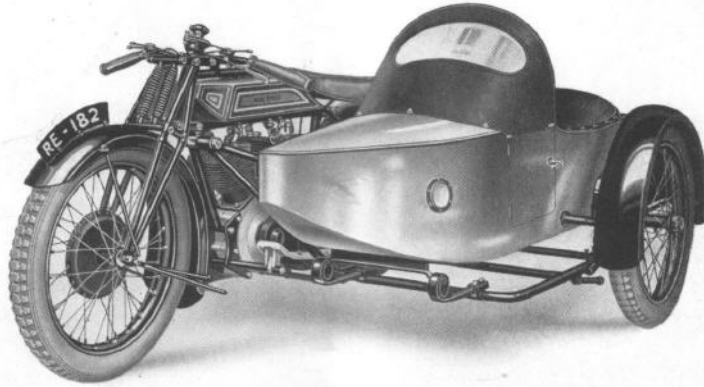

Sports Sidecar for Model 182

CHASSIS.—Enfield design, very strong and rigid, but easily detachable. Beautifully sprung. Stand fitted.

TYRE.—Dunlop Cord 26 × 3.25 in.

BODY.—Polished aluminium panels. Upholstered in black leather cloth. Hammock seat. Locker for tools

and spares behind seat back. While of sporting line, this body is roomy and comfortable. A door is provided, also a Windscreen. A wide Mud-guard is attached to the body.

WEIGHT of Sidecar, Chassis, etc., 126 lbs.

Price £15 10 0 net cash

or £3 18s. 3d. down, and twelve monthly instalments of £1 1s. 2d., including Insurance.

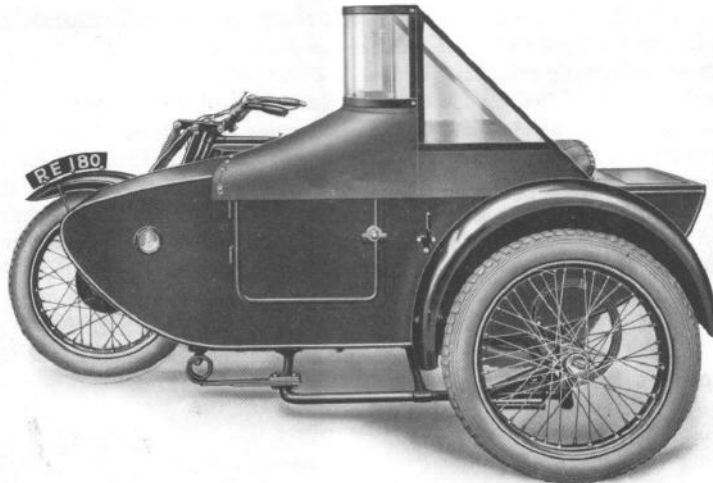

Touring Sidecar for Model 180

CHASSIS.—As above.

TYRE.—Dunlop Cord 26 × 3.25 in.

BODY.—Exceptionally strong and well-made coach-built body, with roomy locker at rear. Black leather cloth

upholstery, and curved celluloid windscreen with side curtains. Mud-guard attached to body.

WEIGHT of Sidecar, Chassis, etc., 154 lbs.

Price £17 10 0 net cash

or £4 8s. 6d. down, and twelve monthly instalments of £1 3s. 11d., including Insurance.

OVERALL LENGTH of either of above Combinations, 7 ft. 2 in.
OVERALL WIDTH of either of above Combinations, 5 ft. 3 in.

ROYAL ENFIELD

MADE LIKE A GUY

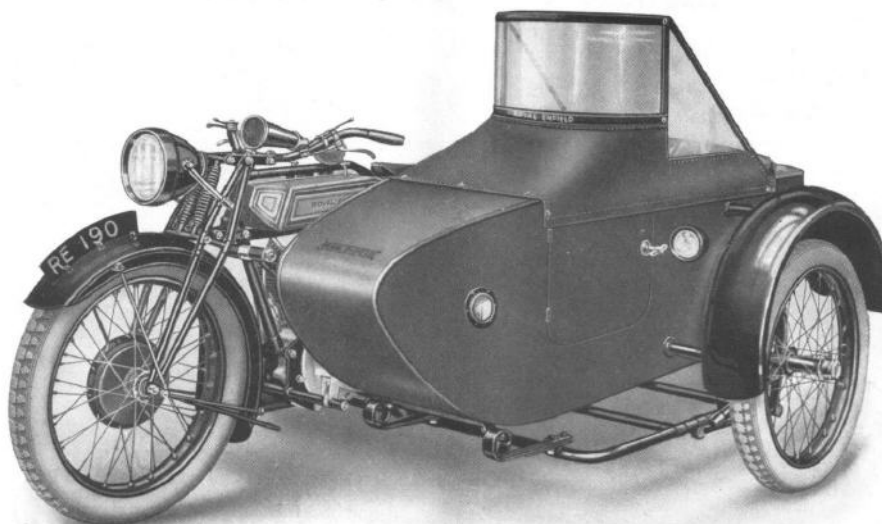

9.76 h.p. De-Luxe Combination Model 190

THE general specification of this Model is similar to that of the standard machine described and illustrated on page 16. It is, however, sold as a complete combination, electrically equipped and ready for the road. Electric lighting is admittedly the ideal means of illumination for motor cycles, now that lighting sets are so universally reliable. The extra cost when purchasing a new machine is more than outweighed by the cleanliness and ease of manipulation.

All three lamps can be switched on without leaving the saddle, and it is possible, owing to the incorporation of two distinct filaments in the head lamp, to have either a powerful or subdued light. The reduced light is useful when riding through towns, or if the machine is left standing in the street at night. The lighting and ignition system for this machine is the well-known Lucas "Magdyno" set, and the additions to the specification of Model 180 are as follows:—Dynamo, battery (in the sidecar), head lamp, incorporating switchbox, sidecar lamp, rear lamp, and ebony black bulb horn. The head lamp is fixed by stout struts to the front fork. The sidecar lamp has concealed cables, and the bulb in the rear lamp is mounted on a rubber diaphragm, which absorbs vibration.

Weight of Motor Cycle, 315 lbs.

Weight of Sidecar, Chassis, etc., 175 lbs.

Overall length of Combination, 7 ft. 2 in.

Overall width of Combination, 5 ft. 3 in.

Price - - £95 0 0 net cash

or **£25 14s. 9d.** down, and twelve monthly instalments of
£6 19s., including Insurance.

Legshields (illustrated on page 20), **15s.** extra.

Dunlop Cord Balloon Tyres, **£3** extra.

ROYAL ENFIELD

MADE LIKE A GUN

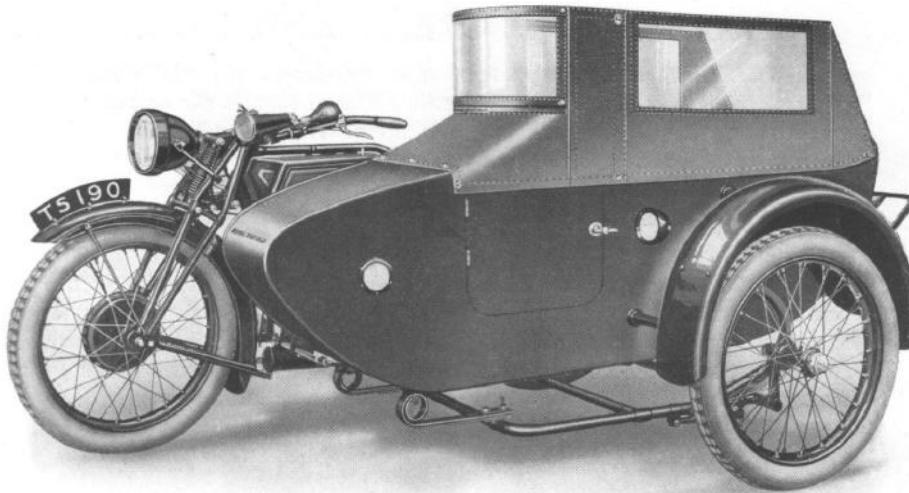

TWO-SEATER SIDECARS

The Sidecar illustrated above can be supplied with either Model 180 or Model 190. It is designed to carry an adult and a child seated tandem fashion. A small seat is placed in front of the ordinary one. The back-rest of this front seat folds out of the way when passengers are entering or leaving the sidecar. A strong metal luggage grid is attached to the body, the grid folding up neatly when not in use. A slightly wider chassis is supplied with a two-seater sidecar body.

It will readily be seen from the illustration above that the windscreen provided has excellent side curtains, protecting both passengers. The screen opens with the door and the side curtains remain in position.

Overall length of Two-Seater Combination, 7 ft. 8 in. ; width, 5 ft. 6 in.

Price - £4 0 0 extra

GRADUAL PAYMENT EXAMPLE.—Model 180 with two-seater body, £88 net cash, or £23 19s. 6d. down, and twelve monthly instalments of £6 9s. 6d., including Insurance.

The lower illustration is of a larger body built to carry two adults. It is several inches longer than the one illustrated and described above, the front seat extending the whole width of the body. In other respects the sidecars are alike.



Overall length of Adult Two-Seater Combination, 7 ft. 9 in. ; width, 5 ft. 6 in.

Price - £5 5 0 extra

ROYAL ENFIELD

MADE LIKE A GUY

SPECIAL WINDSCREEN AND HOOD

ALL-WEATHER equipment, consisting of wooden-framed windscreen and collapsible hood, can be supplied with either of Models 180 or 190, when required, at an extra charge. The screen is easily adjustable to any angle required by merely turning two wing nuts. The hood, made of black waterproof material on a metal frame, can be raised or lowered in a few seconds. Side curtains clip on to the windscreen and can be left in position while the hood is folded out of use, or placed in the locker as desired.

The illustration shows the standard sidecar with hood, screen, and side curtains in position. An absolutely enclosed compartment is thus provided for wet weather. The two-seater sidecar can be similarly equipped, having one or two windscreens, as required. In this case the hood is, of course, larger, and the side curtains longer; otherwise the design is similar to that for the single-seater sidecar body.

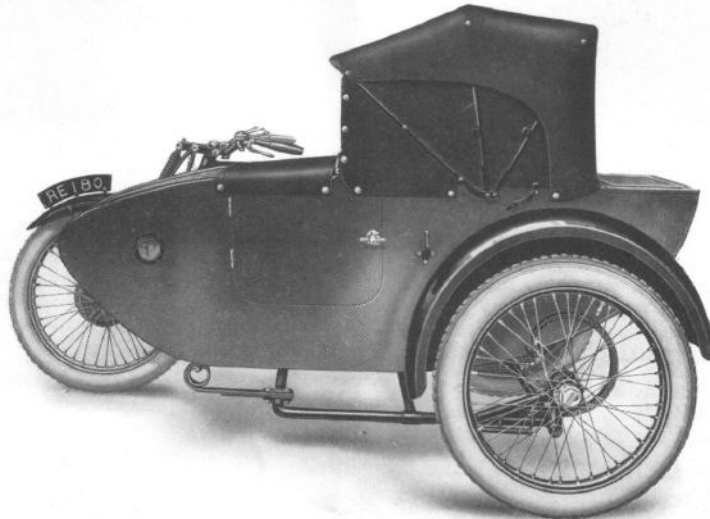

	£	s.	d.
Windscreen and Side Curtains only	2	5	0
Hood, Windscreen, and Side Curtains	5	15	0
Ditto	6	5	0
Ditto for Two-Seater Sidecar	6	5	0
Rear Windscreen for Two-Seater Sidecar	2	5	0

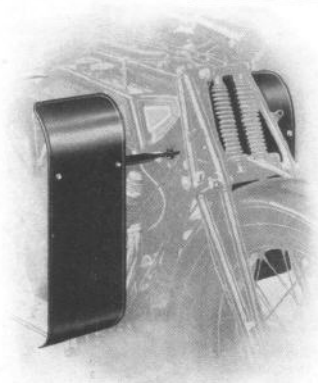

LEGSIELDS

Useful but attractive Legshields, specially designed for use with Royal Enfield 9.76 h.p. Motor Cycles, can be fitted to either of these Models. For the all-weather rider, these legshields will prove very beneficial. They can be supplied on a new machine or be purchased separately, complete with all necessary fittings.

Price - 15s.

ROYAL ENFIELD

MADE LIKE A GUN

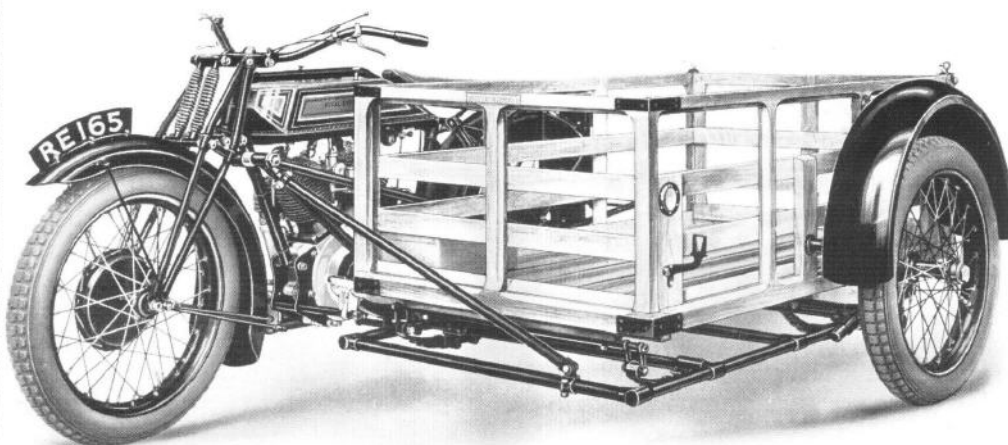

9.76 h.p. Dairyman's Combination Model 165

We have sold large quantities of this type of outfit to dairymen, farmers, and green-grocers. It is the standard 9.76 h.p. Royal Enfield, with a wide and exceptionally strong chassis, having two additional points of attachment. This enables a milk float to be attached which is capable of carrying three milk churns, besides cans, tools, spares, etc. Dimensions of milk float body: length, 4 ft. 6 in.; width, 2 ft. 10 in.; depth, 1 ft. 7 in. Weight of Milk Float, Chassis, etc., 196 lbs. Overall length of Combination, 7 ft. 2 in.; width, 6 ft.

Price £85 0 0 net cash

or by gradual payments; particulars on request.

Model 175 is a similar outfit, but on the standard chassis, the length and width being the same as the box carrier on the previous page.

This is designed to carry two milk churns instead of three, and is invaluable to the man with a smaller business. **Price** is the same as that of Model 185, i.e., £84.

Model 155, with very large box carrier, was originally designed for the G.P.O. Authorities, who have taken delivery of numbers of these machines. Bakers, grocers, and caterers also find them of great assistance. They are designed to

carry 3-4 cwt. The strongly-made box has a lid in front and double doors at the rear. Lettering on the box can be executed at a small extra charge. Dimensions of box: length, 4 ft. 9 in.; depth, 3 ft. 3 in.; width, 2 ft. 9½ in. Capacity approx. 31 cubic feet.

Weight of carrier, chassis, etc., 245 lbs.

Overall length and width as Model 165.

Price £95
net cash

or by gradual payments;
particulars on request.

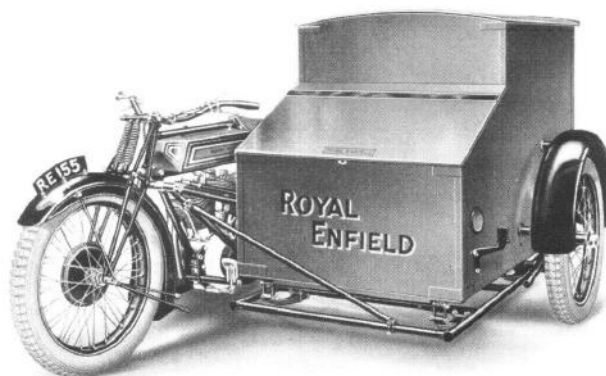

ROYAL ENFIELD

Guarantee

W^hereas the guarantee with our Motor Cycles, Motor Cycle Combinations and Sidecars is given in place of any implied conditions, warranties or liabilities and this guarantee is to extend and be in force for three months only from the date of purchase, and the damages for which we make ourselves responsible under this guarantee are limited to the free supply of a new part manufactured by us in exchange for the part of the motor cycle which may have proved defective. We do not undertake to replace or refix or bear the cost of replacing or refixing such new part in the motor cycle. We undertake, subject to the conditions mentioned below, to make good at any time within three months any defects in these respects. As motor cycles are easily liable to derangement by neglect or misuse, this guarantee does not apply to defects caused by wear and tear, misuse or neglect. The term "misuse" shall include, amongst others, the following acts:—

1. The attaching of a sidecar to the motor cycle in such a manner as to cause damage or calculated to render the latter unsafe when ridden.
2. The use of a motor cycle or of a motor cycle and sidecar combined, when carrying more persons or a greater weight than that for which the machine was designed by the manufacturers.

In respect of repairs and replacements of our own manufacture, we give the following guarantee, instead of and to the exclusion of the guarantee implied by statute or otherwise, that is to say:— Any motor cycle sent to us to be plated, enamelled or repaired, whether the repairs are required for the purpose of making good the defect before referred to or otherwise, will be repaired upon the following conditions, i.e., we guarantee that all precautions which are usual and reasonable have been taken by us to secure excellence of material and workmanship, such guarantee to extend and be in force for three months only from the time such work shall have been executed, and this guarantee is in lieu and in exclusion of any common law or statute warranty, and the damages recoverable are limited to the cost of any further work which may be necessary to amend and make good the work found to be defective.

CONDITIONS OF GUARANTEE:

If a defective part should be found in our motor cycles, or in any part replaced, it must be sent to us carriage paid, and accompanied by an intimation from the sender that he desires to have it repaired free of charge under our guarantee, and he must also furnish us at the same time with the number of the machine, the name of the dealer from whom he purchased and the date of the purchase, or the date when the alleged defective part was replaced, as the case may be. Failing compliance with the above, no notice will be taken of anything which may arrive, but such articles will lie here at the risk of the senders, and this guarantee, and any implied guarantee, shall not be enforceable.

We do not guarantee specialities of other firms or any component parts supplied to the order of the customer differing from our standard specification. We do not appoint agents for the sale of our motor cycles, motor cycle combinations, sidecars, or other goods. We assign to motor cycle dealers (styled "regional" dealers), who carry on business on their own account, areas in which they have an exclusive or other right to sell goods purchased from us. The regional dealer purchasing from us, or a sub-dealer purchasing from him may, on our behalf (as our agent for this purpose only) give the guarantee printed above. Any such dealer is not authorised to advertise, incur any debts, or transact any business whatever on our account, nor is he authorised, so as to bind us, to give any guarantee or make any representation on our behalf, or to sell subject to or with any conditions other than those contained in such guarantee.

CONDITIONS OF SALE

The prices appearing in this catalogue are STRICTLY NET. All goods are sold subject only to the conditions of guarantee given above. The Royal Enfield Motor Cycle and Sidecar Combinations are sold subject to the further condition that we cannot accept responsibility if used with any sidecars other than the ones supplied by us. The 2.25 h.p. Model is sold subject to the further condition that we cannot accept responsibility if it is used with a sidecar, of whatsoever make or type. The prices and specifications in this list are subject to alteration at any time without previous notice.

PAYMENT.—One-third deposit must be paid on our acceptance of the order, and the balance upon receipt of our advice that goods are ready for despatch.

CARRIAGE.—1. All machines are sent Carriage Paid to the nearest railway station.

2. Notwithstanding payment of carriage, all goods are to be considered as delivered to the customer when put on rail at Redditch Station, and all orders are accepted and executed upon this understanding.

3. Upon receipt of goods by customer, it is essential that the Railway Company's Delivery Sheet should in all cases be signed "not examined." The goods should then be carefully inspected, and in the event of any damage, notice should at once be sent to the Carriers and claim made from them.

4. We reserve the right to despatch either by Goods or Passenger Train, but when machines are sent by Goods Train in Crates, the Crates are charged, and half the amount charged is allowed when returned in good condition.

5. Cases and Crates for shipment abroad are charged at Cost Price.

REPAIRS AND SUNDRIES.—These cannot be booked; our terms are net cash on receipt of pro forma invoice. Machines or parts for repair must be sent carriage paid, and the name of the sender attached, or they cannot be received. Full instructions, with advice as to mode of despatch, should be posted same day. When ordering spare parts or sundries, customers are respectfully requested to quote our identification number for each part required; it is also necessary that the number of the machine and number of engine should in all cases be given. Please mark any communication relating to repairs or sundries:—"Service Department."

ROYAL ENFIELD

MADE LIKE A GUN

A few successes during 1926.

SOUTH AFRICAN T.T. RACES.

FIRST IN 350 C.C. RACE. FIRST IN 600 C.C. RACE

SCOTTISH SIX DAYS' TRIAL.

1 SILVER CUP. 1 GOLD MEDAL.

INTERNATIONAL SIX DAYS' TRIAL.

TWO GOLD MEDALS.

"HUTCHINSON" HUNDRED MILES RACE.

FIRST.

ULSTER GRAND PRIX.

Handicap Cup and Replica of Trophy.

Czecho-Slovakian T.T. Races.—First in 350 c.c. Race.
Colmore Cup Trial.—1 Gold Medal; 1 Silver Medal.
Ramblers' M.C.C. Trial.—Silver Vase.
Yorkshire News Trial.—Silver Watch.
Victory Cup Trial.—2 Gold Medals.
Dublin University M.C.C. Open Trial.—First Class Award.
Dublin and District M.C.C. Open Trial.—First Class Award.
Tunbridge Wells M.C.C. Trial.—Best Solo Performance; Best Novice Performance.
Redditch M.C. and C.C. Open Trial.—Nife Cup; 2 Gold Medals.
Luton and District M.C. Trial.—Dandy Cup.
M.C. and A.C. 24 Hours' Trial.—1 Gold Medal; 1 Silver Medal.
Athy M.C. and C.C. Speed Trial.—1 First Prize; 1 Second Prize.
Southport M.C. Speed Trial.—First in 850 c.c. Flying Kilo.
Travers Trophy Trial.—Gold Medal.
Natal M.C.C. Hill Climb.—3 First Prizes.
Cheshire Centre, A.C.U. Trial.—Gold Medal.
Garshaiton Pillion Trial.—Silver Cup.
London-Land's End Trial.—2 Gold Medals; 7 Silver Medals.
Tadcaster M.O. Hill Climb.—4 First Prizes.
Scarboro' Two Days' Trial.—Best Solo Performance; Silver Rose Bowl; Silver Vase; Silver Cup.
Leinster M.O. and C.C. Novice Trial.—3 Gold Medals.
S.E. Durham M.C.C. Speed Trial.—3 First Prizes.
Kiockham Memorial Open Trial.—John Bull Cup; 2 Silver Cups.
Races at Budapest.—First in 350 c.c. Class.
Knowle and District M.O. Trial.—Whitmore Trophy.
Hendon Athos M.C. Steeplechase.—Silver Cup and Medal.
Race Round Denmark, Three Days.—First Prize.
Knock M.C.C. All-night Run.—Silver Vase.
Bradford-London-Bradford Run.—3 Silver Cups.
Bearwood Amateur M.C.C. Trial.—Frank Hallam Cup.
Knock M.C.C. Five Miles' Championships.—First in 350 c.c. Championship.
Irish Championships at Magilligan.—2 Championships (50 miles); First in 50 Miles Handicap.
Dublin University M.C.C. Hill Climb.—1 First Prize; 2 Second Prizes.
Dordrecht Races, Holland.—2 First Prizes.
Cheshire Centre A.C.U. Races at Southport.—First in 25 Miles Race, 350 c.c.; 2 Second Prizes.
Athy M.C. and C.C. 75 Miles Race.—Fastest Time in 350 c.c. Class.
Tadcaster M.O. Speed Trials.—2 First Prizes; Fastest time of the day.
Southport M.O. 50 Miles Races.—First in 350 c.c. Race.
Irish 25 Miles' Championships.—First in 350 c.c. Sidecar Championship.
Dungannon M.C.C. 100 Miles Race.—Fastest time of the day.
Yorkshire Centre, A.C.U. Speed Trial.—1 Championship; Gold Cup; First in 4 Miles Race, 250 c.c.
N. Liverpool M.C.C. Races.—2 First Prizes.
Hartlepool M.C.C. Speed Trials.—3 First Prizes; 1 Second Prize.
Bradford M.O.C. Freak Hill Climb.—4 First Prizes.
York and District M.O. Speed Trial.—First. Fastest time of the day, 250 c.c.
Irish 100 Miles Championships.—First in 350 c.c. Championship.
Rand M.C.C. (S. Africa) Races.—First in 5 Miles Scratch Race (350 c.c.).
Dublin and District M.C.C. Speed Trials.—First in 350 c.c. Class.
Presteigne A.C. Trial.—Best Sidecar performance.
Tadcaster and D.M.C. Speed Trials.—5 First Prizes; 5 Second Prizes.
Wye Valley A.C. Trial.—H.A.C. Bowl.
Irish 10 Miles Championships.—2 Championships First in 25 Miles Race.
Leinster M.C. and C.C. Trial.—2 First Class Awards.
M.C.C. High-Speed Test, Brooklands.—Gold Medal.
Ashford M.C. Trial.—President's Cup.
Western Centre Trial.—2 First Class Awards. Share of Dunlop Team Trophy.
Redditch M.C. and C.C. Trial.—Huins Cup; Garages Cup; 2 Gold Medals.
N. Wilts. M.C. Trial.—Goodyear Cup.
Camberley and District M.C. Trial.—Silver Cup.
Levis A.C. Trial.—First Class Award.
Southampton M.C. and L.C.C. Trial.—Angus Cup.
London-Gloucester-London Trial.—Silver Cup; 2 Silver Spoons.
Dublin University Trial.—Gold Medal.
Drogheda and District M.C.C. Trial.—Tredagh Cup and Replica.
London-Exeter-London Trial.—1 Gold Medal; 2 Silver Medals.